



## Heater Jackets Greatly Improve Vacuum Line Performance

**Nor-Cal is Your Source for Stock Standard and Custom Heater Jackets**

Heater jackets, controllers and accessories from Nor-Cal Products reduce build-up of semiconductor process by-products in valves and other exhaust line components, while reducing particle generation and system downtime.

### Features

- Even heating up to 200°C
- Easy on, easy off with reclosable fasteners
- Tight contact fit
- Silicone rubber construction
- Modular heating system
- UL® recognized construction
- Trimable materials
- Integrates with standard control consoles
- Built-in insulation
- 1 year warranty

### Benefits

- Fewer particles, reduced system downtime
- Improved heat transfer minimizing cold spots
- Clean room compatible
- Combine standard parts to cover custom lines
- Adjustable temperatures

Thermocouple pocket is built-in to all straight length heaters three inch long and greater. Shown with optional thermocouple installed.



All trimable jackets allow for up to one inch of insulation to be removed. This allows you to cover almost any line completely.

Self-adhesive kapton thermocouples are available for heaters without thermocouple pockets.

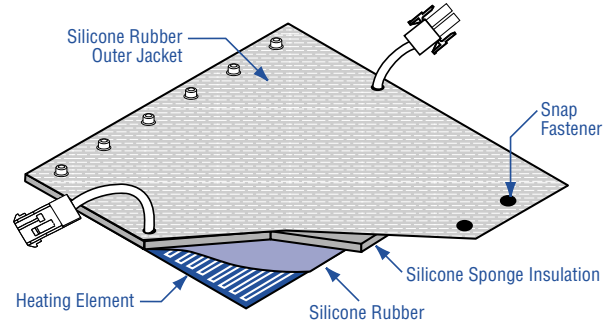

### Physical Specifications

- Heater and jacket material is a reinforced silicone rubber fabric
- Insulation material: 1/4 inch closed-cell silicone rubber foam.
- Color: grey insulation and outer jacket, red heater
- Fasteners: snap type: 1/2 inch nominal diameter metal construction with nylon cover
- Thermocouple pocket is built-in to all straight length heaters three inches long and greater, one per heater
- Self-adhesive kapton thermocouples are available for heaters without thermocouple pockets
- Nominal thickness: .35 inch (0.80 inch including snaps)
- Maximum operating temperature 200°C

### Electrical Specifications

- Watt density: 1 to 2 W/in<sup>2</sup> typical
- 120 V / 240 V standard, other voltages available
- Power lead wires: 4 in. #18 AWG UL 1180/CSA Teflon® insulated, rated 10A, leadwire pair encapsulated in reinforced silicone rubber sleeving
- Connectors: positive locking Amp Universal Mate-N-Lok® connector, 3 position, rated 10A. Other connectors available on request
- Heaters are interconnectable up to a 10A circuit

Typical Steady State Outer Surface Temperature vs. Internal Temperature for Silicone Rubber Heaters, 1/4 inch Insulation, 20°C Ambient

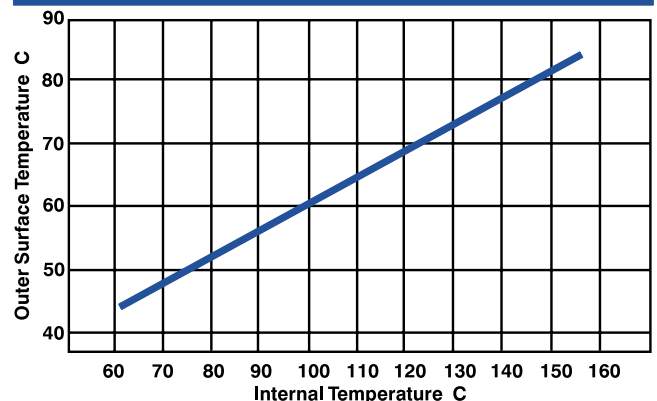

Prices subject to change without notice. - International product pricing will vary.

THERMAL-LIT 11/01



**Many semiconductor processes can benefit from heated foreline and exhaust lines. Silicon nitride and TEOS LPCVD and aluminum or tungsten metal etch are the most common processes requiring heated pump lines.**

## Silicon Nitride and TEOS LPCVD

For silicon nitride LPCVD, heating the line over 110°C from the process to the dry-pump can greatly reduce the amount of solids which build up in the line. TEOS LPCVD lines should be heated to 150°C. This extends PM intervals and reduces wafer defects in the process chamber by up to 10 times.

Preventative maintenance schedules can be extended several times, meaning larger numbers of runs between line cleanings. The heated foreline will no longer catch the majority of the condensable by-products, which can sublime in the pump. For most applications, it is highly recommended that the dry-pump is protected by a foreline trap upstream from the pump (reference 2 and 4 on chart below). Nor-Cal offers standard and custom water-cooled and particulate foreline traps for most semiconductor applications.

## Aluminum or Tungsten Metal Etch

When heating lines for metal etch applications, keeping the lines above 90°C can greatly reduce the metal and salt build-up. This minimizes wafer defects and extends preventative maintenance schedules. For metal etch, heating both the foreline from the process tool to the pump, and the pump exhaust line to the scrubber will yield the best results (reference 1 on chart below). Heating other components, such as pump mufflers, is also beneficial and helps to reduce downtime.

*Variations in process equipment, process parameters and component temperature ratings will dictate different system solutions. Always review equipment specifications and process parameters before determining temperature specifications and heated line design. Failure to follow the required specifications and parameters could result in equipment damage or undesired process results.*

## Typical Variations of Foreline and Exhaust Configurations

- 1 Heated foreline to pump and heated exhaust line to scrubber. No foreline trap
- 2 Heated foreline to foreline trap before pump
- 3 Heated foreline to pump and heated exhaust to foreline trap after pump
- 4 Heated foreline to foreline trap

Refer to the Nor-Cal Foreline Traps catalog for more information on line design.

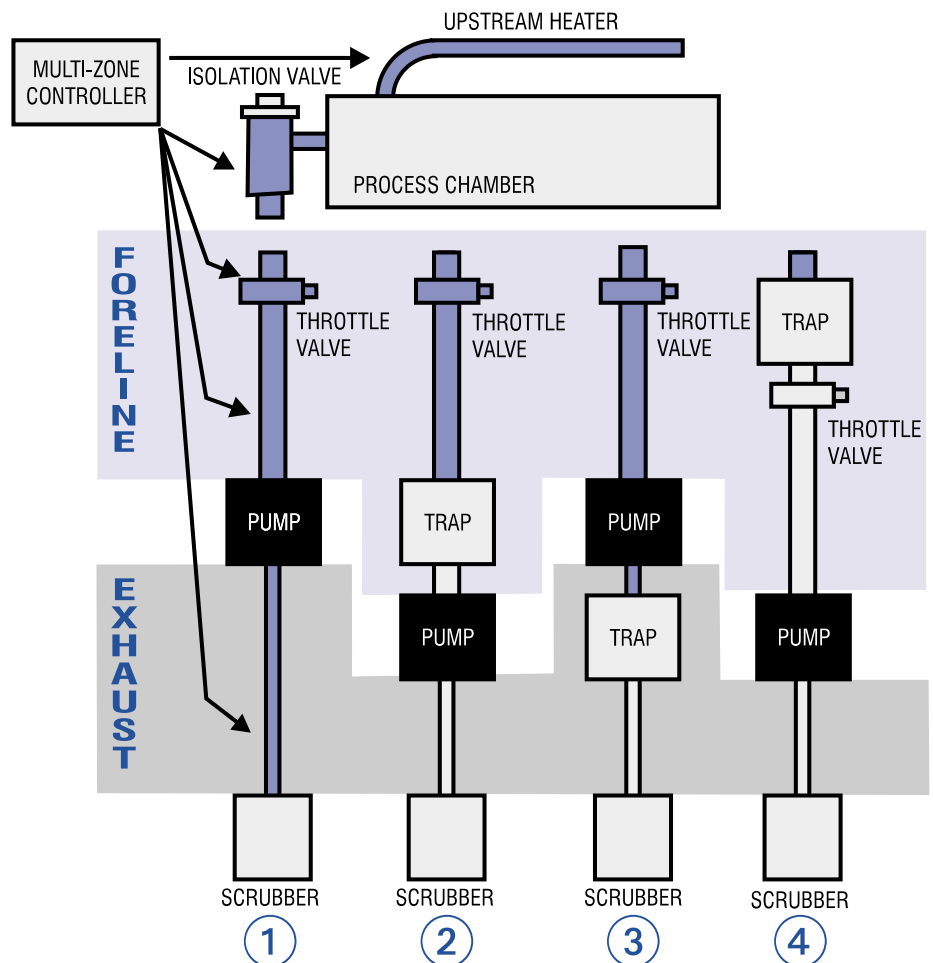



## HEATED FORELINE

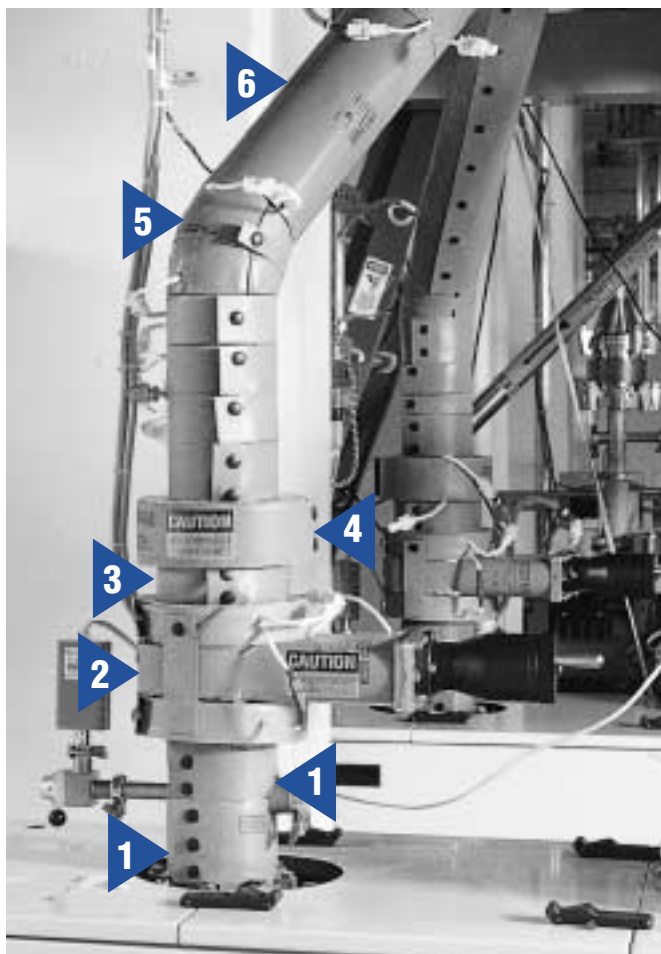

- 1 Trimable Lengths for Test Ports and Gauges
- 2 Gate Valve Heater
- 3 Bellows Heater
- 4 Flange Heater
- 5 45° Elbow Heater
- 6 24 inch Straight Section

## MEASUREMENT & SELECTION

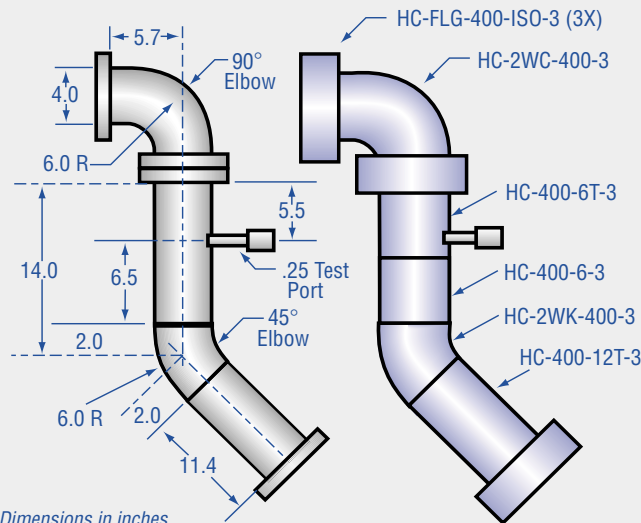

## Line Measurement

To achieve the maximum benefit from your Nor-Cal heating system, 100% heated coverage is needed. To accomplish this, measurement of the vacuum line is necessary.

For best results, please contact your Nor-Cal representative to set up an appointment to measure your line. Use the following guidelines to develop an approximate measurement that can be used for component selection and control zone layout.

**NOTE:** To measure quickly, start at one end of the line and work your way to the other end. Measure one component at a time. Drawings of each component are not necessary if detailed measurement notes are taken.

**DIAMETER:** Verify the diameter of your line by measuring the circumference (distance around the outside of the tubing) of a common straight section within the line.

Diameter	Circumference
1.50"	4.71"
2.00"	6.28"
3.00"	9.42"
4.00"	12.57"

**STRAIGHT SECTIONS:** Measure the length of a straight section referencing the backside of the flange or the centerline of the butt-weld joint.

**45° and 90° ELBOWS:** Measure the "L" dimension from the backside of the flange to the centerline of the opposing leg. Please refer to specific heater drawings located in this product guide.

**TEE:** Measure the length "L" as shown in this guide.

### FLEXIBLE SECTIONS:

Measure the outer diameter of the bellows and the length as shown in the specific heater drawings located in this product guide. **Note:** the length must be measured under compression with full vacuum pulled. If there is a noticeable "twisting" on the flexible section, adjustment of the line may be needed for proper heater installation.

**FLANGE:** Note flange type and measure dimensions.

**VALVES and OTHER SHAPES:** Nor-Cal has a large selection of existing heater designs for valves, reducers and other miscellaneous components.



## Heater Jacket Selection

- After measuring your system using the instructions above, choose the heater segments you will need to cover your exhaust line from this product guide. List the model numbers with your notes.
- Trimable heaters solve the problem of odd straight section lengths. For example, for a 14.5 inch section, combine a 12 inch trimable and a 3 inch heater. The 12 inch heater can be cut to a minimum of 11 inches. Cut .5 inch from the 12 inch heater to make a 11.5 inch length. Place cut edge towards the 3 inch heater to maximize temperature uniformity.

## Zone Layout and Heater Installation

- Heaters can be connected together end-to-end in order to form a larger single circuit which then can be controlled as one "zone."
- A single line may contain multiple zones, depending on the length and the complexity. Use the following rules of thumb when grouping sets of heaters into zones.
- The maximum amperage per zone is 10 amps, or 1200 watts. Please use the part number list to calculate the total wattage of your heated line. Dividing by 1080 will give you the approximate number of zones required.
- Split the zones at natural break points, such as at a flange, elbow or valve.
- Each component, such as a gate valve, needs to be controlled with a separate control circuit. This is due to the difference in thermal mass between them and lengths of tubing.
- Temperature sensors (thermocouples) can be placed easily in any straight heater three inches long and up. These heaters have a built-in thermocouple pocket for easy installation of the sensor. Self-adhesive kapton thermocouples are available for heaters without thermocouple pockets.
- Remove labels and residual glue with methanol or another solvent before attaching the heater jacket. **Operating the heater on a component with a label can cause discoloration or scorching of the jacket and may cause the label to ignite and damage the heater.**
- When choosing where to place the thermocouples for each zone, start at the process tool, placing the first thermocouple two to four feet from the outlet of the process.
- The jacket should fit tightly for optimum heat transfer. Loose areas can draw higher wattage and damage the insulation and/or heater element. **Note:** Heater must be attached to the component when in operation.
- Do not immerse the heaters in water or cleaning solutions.

*A helpful Heater Design Worksheet is posted on our Website at [www.n-c.com](http://www.n-c.com). Look under Thermal Products.*

## HEATED EXHAUST LINE

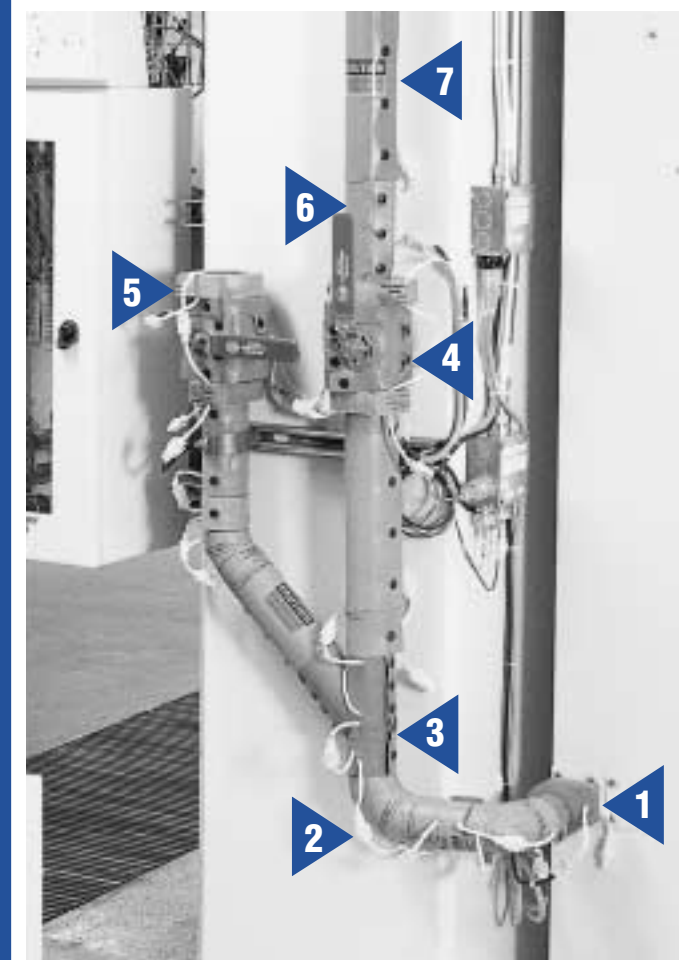

- ▶ 1 2 inch by 1.5 inch Conical Reducer
- ▶ 2 90° Elbow
- ▶ 3 Y Heater
- ▶ 4 Ball Valve Heater
- ▶ 5 Flange Heater
- ▶ 6 Trimable Length
- ▶ 7 36 inch Straight Section

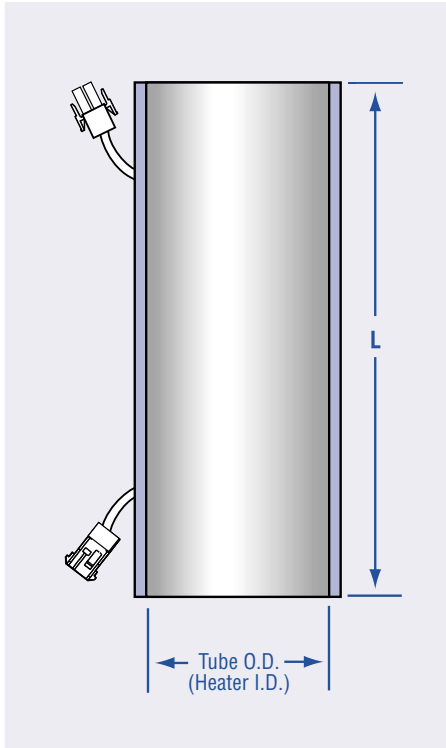

## Straight Tube Heater Jackets - 1.5" O.D.

Model Number	Length "L"	Watts @ 120V	Features	Price
HC-150-2-3	2.00	14		
HC-150-2T-3	2.00	7	Trimable	
HC-150-3-3	3.00	22		
HC-150-3T-3	3.00	14	Trimable	
HC-150-4-3	4.00	29		
HC-150-4T-3	4.00	22	Trimable	
HC-150-5-3	5.00	36		
HC-150-5T-3	5.00	29	Trimable	
HC-150-6-3	6.00	43		
HC-150-6T-3	6.00	36	Trimable	
HC-150-12-3	12.00	85		
HC-150-12T-3	12.00	78	Trimable	
HC-150-18-3	18.00	128		
HC-150-24-3	24.00	170		
HC-150-24T-3	24.00	163	Trimable	
HC-150-30-3	30.00	213		
HC-150-36-3	36.00	255		
HC-150-36T-3	36.00	248	Trimable	

Dimensions in inches

## Straight Tube Heater Jackets - 2.0" O.D.

- Standard heaters feature a .25 inch wall silicone rubber sponge insulation
- Trimable heaters have a one inch cut-to-length section at one end
- All heaters listed are designed for 120 volt operation. Other voltages available
- A thermocouple pocket is built-in to all straight length heaters three inches long or greater
- Thermocouple pocket allows installation of the temperature sensor
- .50 inch silicone rubber sponge insulation available

Model Number	Length "L"	Watts @ 120V	Features	Price
HC-200-2-3	2.00	19		
HC-200-2T-3	2.00	10	Trimable	
HC-200-3-3	3.00	29		
HC-200-3T-3	3.00	19	Trimable	
HC-200-4-3	4.00	38		
HC-200-4T-3	4.00	29	Trimable	
HC-200-5-3	5.00	48		
HC-200-5T-3	5.00	38	Trimable	
HC-200-6-3	6.00	57		
HC-200-6T-3	6.00	47	Trimable	
HC-200-7T-3	7.00	57	Trimable	
HC-200-8T-3	8.00	68	Trimable	
HC-200-9T-3	9.00	75	Trimable	
HC-200-10T-3	10.00	85	Trimable	
HC-200-11T-3	11.00	95	Trimable	
HC-200-12-3	12.00	114		
HC-200-12T-3	12.00	104	Trimable	
HC-200-18-3	18.00	170		
HC-200-24-3	24.00	227		
HC-200-24T-3	24.00	217	Trimable	
HC-200-30-3	30.00	283		
HC-200-36-3	36.00	340		
HC-200-36T-3	36.00	330	Trimable	

Dimensions in inches



## Straight Tube Heater Jackets - 3.0" O.D.

Model Number	Length "L"	Watts @ 120V	Features	Price
HC-300-2-3	2.00	24		
HC-300-2T-3	2.00	12	Trimable	
HC-300-3-3	3.00	36		
HC-300-3T-3	3.00	24	Trimable	
HC-300-4-3	4.00	48		
HC-300-4T-3	4.00	36	Trimable	
HC-300-5-3	5.00	59		
HC-300-5T-3	5.00	48	Trimable	
HC-300-6-3	6.00	71		
HC-300-6T-3	6.00	59	Trimable	
HC-300-12-3	12.00	141		
HC-300-12T-3	12.00	129	Trimable	
HC-300-18-3	18.00	213		
HC-300-24-3	24.00	283		
HC-300-24T-3	24.00	271	Trimable	
HC-300-30-3	30.00	354		
HC-300-36-3	36.00	425		
HC-300-36T-3	36.00	413	Trimable	

Dimensions in inches

## Straight Tube Heater Jackets - 4.0" O.D.

Model Number	Length "L"	Watts @ 120V	Features	Price
HC-400-2-3	2.00	32		
HC-400-2T-3	2.00	16	Trimable	
HC-400-3-3	3.00	48		
HC-400-3T-3	3.00	32	Trimable	
HC-400-4-3	4.00	63		
HC-400-4T-3	4.00	48	Trimable	
HC-400-5-3	5.00	79		
HC-400-5T-3	5.00	63	Trimable	
HC-400-6-3	6.00	95		
HC-400-6T-3	6.00	79	Trimable	
HC-400-7T-3	7.00	95	Trimable	
HC-400-8T-3	8.00	114	Trimable	
HC-400-9T-3	9.00	130	Trimable	
HC-400-10T-3	10.00	146	Trimable	
HC-400-11T-3	11.00	157	Trimable	
HC-400-12-3	12.00	189		
HC-400-12T-3	12.00	173	Trimable	
HC-400-18-3	18.00	283		
HC-400-24-3	24.00	377		
HC-400-24T-3	24.00	361	Trimable	
HC-400-30-3	30.00	472		
HC-400-36-3	36.00	566		
HC-400-36T-3	36.00	550	Trimable	

Dimensions in inches

## Heater Design Worksheet

Consider the following questions when designing your heated lines.

What type of components will you be heating?  
Do you have a sample part available for fitting?  
Are drawings available?

What is the application temperature?

What is the maximum component temperature?

What is the maximum external temperature?

What voltage will power heater?

Will temperature need to be adjusted?  
(Accuracy : +/- 10% T/S, +/- 3C T/C)

Are there any special instructions such as safety requirements, unique environment or other issues?

Are you using thermocouples or thermostats?  
If using thermocouples, what type and lead length?

What length power cable is required?

Do you have special power requirements?

Are there multiple temperature zones?

## Cost of Ownership

Please calculate the following information so we may provide you with approximate cost of ownership for your system.

Average number of maintenance intervals per month

Average length of each maintenance session (hours)

Cost of maintenance (labor rate per hour)

How many maintenance and operating personnel are involved

Cost of downtime (lost production in \$\$ per hour)

Cost of current replacement parts and/or refurbishing services per month

A complete printable heater design worksheet is located on our website under Thermal Products.



# HC-SERIES HEATER JACKETS

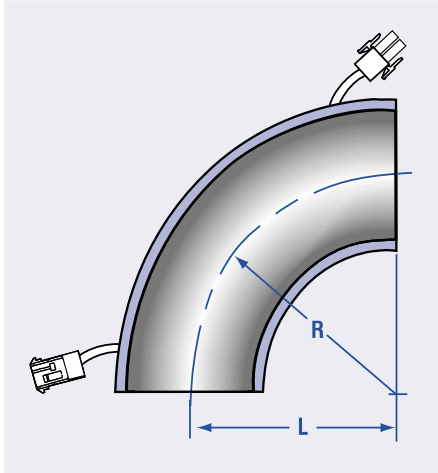

- Standard heaters feature .25 inch silicone rubber sponge insulation
- Elbow and tee heaters will fit both butt-weld and flanged style tubing elbows
- .50 inch silicone rubber sponge insulation is available. Call for information

## 90° Radius Elbow Heater Jackets

Model Number	Tube O.D.	Length "L"	Radius "R"	Watts @ 120V	Features	Price
HC-2WC-150-3	1.5	2.00	2.25	25		
HC-2WC-150HW-3	1.5	2.68	2.25	36	With Tangent	
HC-2WC-200-3	2.0	2.75	3.00	45		
HC-2WC-200HW-3	2.0	3.81	3.00	65	With Tangent	
HC-2WC-300-3	3.0	4.00	4.50	93		
HC-2WC-300HW-3	3.0	5.81	4.50	141	With Tangent	
HC-2WC-400-3	4.0	5.50	6.00	149		
HC-2WC-400HW-3	4.0	7.81	6.00	217	With Tangent	

Dimensions in inches

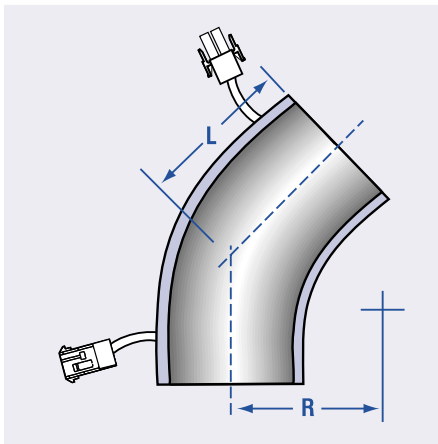

## 45° Radius Elbow Heater Jackets

Model Number	Tube O.D.	Length "L"	Radius "R"	Watts @ 120V	Features	Price
HC-2WK-150-3	1.50	0.69	2.25	13		
HC-2KL-150HW-3	1.50	1.38	2.25	23	With Tangent	
HC-2WK-200-3	2.00	1.00	3.00	23		
HC-2KL-200HW-3	2.00	2.06	3.00	44	With Tangent	
HC-2WK-300-3	3.00	1.37	4.50	47		
HC-2KL-300HW-3	3.00	3.18	4.50	95	With Tangent	
HC-2WK-400-3	4.00	2.00	6.00	70		
HC-2KL-400HW-3	4.00	4.31	6.00	148	With Tangent	

Dimensions in inches

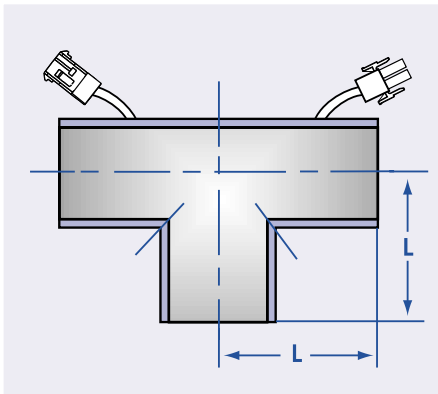

## Tee Heater Jackets

Model Number	Tube O.D.	Length "L"	Watts @ 120V	Price
HC-7W-150-3	1.50	2.00	37	
HC-7W-200-3	2.00	2.75	69	
HC-7W-300-3	3.00	3.00	99	
HC-7W-400-3	4.00	3.63	140	

Dimensions in inches

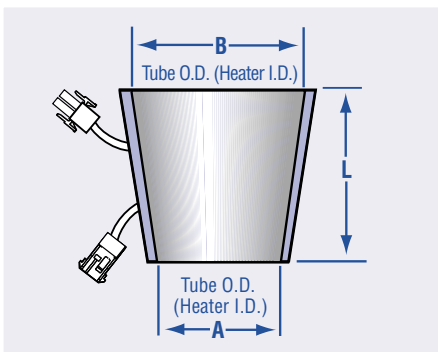

## Conical Heater Jackets

Model Number	A	B	Length "L"	Watts @ 120V	Price
HC-200-150-3	1.50	2.00	1.38	12	
HC-300-200-3	2.00	3.00	2.42	24	
HC-400-200-3	2.00	4.00	2.63	31	
HC-400-300-3	3.00	4.00	2.60	36	

Dimensions in inches

Prices subject to change without notice. - International product pricing will vary.

THERMAL-LIT 11/01



## Flange Heater Jackets

Model Number	Flange Type	Nominal Tube O.D.	Watts @120V	Price
HC-FLG-150-NW-3	NW-40	1.5	10	
HC-FLG-200-NW-3	NW-50	2.0	15	
HC-FLG-300-ISO-3	ISO-80	3.0	35	
HC-FLG-400-ISO-3	ISO-100	4.0	82	

Dimensions in inches

- .25 inch silicone rubber sponge insulation
- For both NW flanges and ISO clamp flanges
- .50 inch silicone rubber sponge insulation available

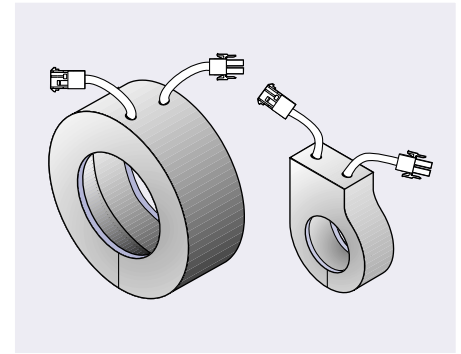

## Flange Insulators

Model Number	Flange Type	Nominal Tube O.D.	Price
HI-FLG-150-NW-1	NW-40	1.5	
HI-FLG-200-NW-1	NW-50	2.0	
HI-FLG-300-ISO-1	ISO-80	3.0	
HI-FLG-400-ISO-1	ISO-100	4.0	

Dimensions in inches

- .25 inch silicone rubber sponge insulation
- For both NW flanges and ISO clamp flanges.
- .50 inch silicone rubber sponge insulation available

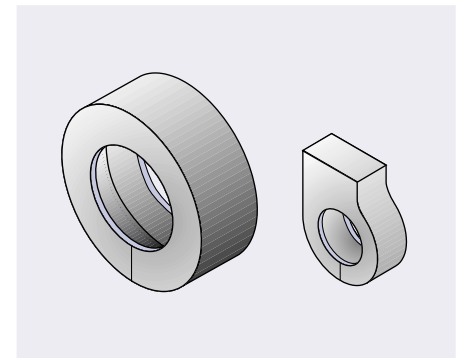

## Heater Jacket Accessories

### Thermocouples and Cables\*

Model Number	Description/Features	Length in Feet	Price
HC-TC-PLG-K	K-type panel mount jack, .50 inch NPT		
HC-TC-K-1	K-type with one foot lead and mini-connector		
HC-TC-K-8	K-type with eight foot lead and mini-connector		
HC-TC-K-KAP-4	K-type kapton with four foot lead and mini-connector		
HC-TC-K-KAP-8	K-type kapton with eight foot lead and mini-connector		
HC-TC-CRD-K-6	K-type thermocouple extension cable with connectors	6	
HC-TC-CRD-K-10	K-type thermocouple extension cable with connectors	10	
HC-TC-CRD-K-25	K-type thermocouple extension cable with connectors	25	

\*Most items available in J-type also. Call for pricing and information



Self-adhesive Kapton thermocouple

### Control Cables and Accessories

Model Number	Description/Features	Length in Feet	Price
HC-PLG	Termination plug for end of last heater		
HC-PCRD-6	Power cable from temperature control console to heater	6	
HC-PCRD-10	Power cable from temperature control console to heater	10	
HC-PCRD-25	Power cable from temperature control console to heater	25	
HT-CRD-6	Power cable from wall plug to AMP connector	6	
HT-CRD-10	Power cable from wall plug to AMP connector	10	
HC-JCRD-6	Power cable, male 3-pin. Use with HC-PLG-JCRD below	6	
HC-JCRD-12	Power cable, male 3-pin. Use with HC-PLG-JCRD below	12	
HC-PLG-JCRD	Female power receptacle, 3-pin, fits .50 NPT		

Prices subject to change without notice. - International product pricing will vary.

THERMAL-LIT 11/01



# HC-SERIES GAS LINE HEATER JACKETS & INSULATORS



Nor-Cal's upstream gas line heaters and insulators offer quick delivery from stock for heating gas delivery lines, such as BCL<sub>3</sub> and WF<sub>6</sub>. They are made from silicone rubber heater material insulated with closed cell silicone rubber sponge and feature quick ON/OFF installation with snap closures. Heaters can be linked/daisy chained to a maximum of 10 amps. Insulators trim-to-fit to insure 100% line coverage. UL® Listed.

- Heater watt density of 2.5 W/in<sup>2</sup>
- Meets UL94HB flammability requirements
- Lead pair extends 3 inches past each end of the heaters
- Optional thermocouples #30 AWG, type J, Teflon® insulated
- Flexible elbow heaters fit any radius elbow

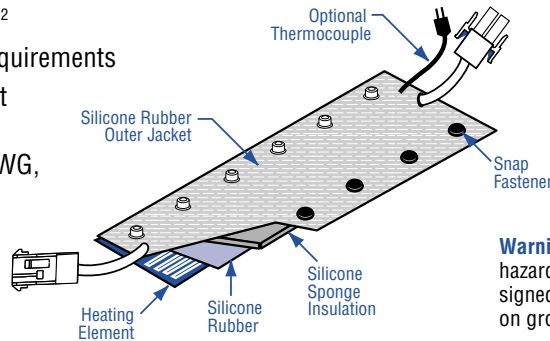

**Warning:** Upstream gas line heater jackets are not designed for hazardous locations or for outdoor locations. They are not designed for total or partial immersion and should only be installed on grounded metallic tubing systems or GFI protected circuit.

## Upstream Gas Line Heater Jackets

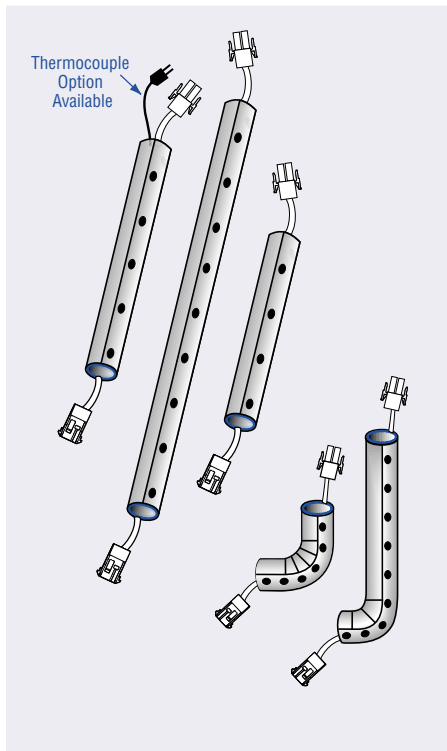

Model Number	Tube O.D.	Length	Watts @120V	Features	Price
HC-025-2WC-1-1	.25	6.0	12	Elbow w/two 1.0 tangents	
HC-025-2WC-5-1	.25	9.0	18	Elbow w/one 5.0 tangent	
HC-025-6-1	.25	6.0	12	Straight	
HC-025-6-TC-1	.25	6.0	12	Straight w/Type J Thermocouple	
HC-025-9-1	.25	9.0	18	Straight	
HC-025-9-TC-1	.25	9.0	18	Straight w/Type J Thermocouple	
HC-025-12-1	.25	12.0	24	Straight	
HC-025-12-TC-1	.25	12.0	24	Straightw/Type J Thermocouple	
HC-025-18-1	.25	18.0	36	Straight	
HC-025-18-TC-1	.25	18.0	36	Straight w/Type J Thermocouple	
HC-025-24-1	.25	24.0	48	Straight	
HC-025-24-TC-1	.25	24.0	48	Straight w/Type J Thermocouple	
HC-025-36-1	.25	36.0	72	Straight	
HC-025-36-TC-1	.25	36.0	72	Straight w/Type J Thermocouple	
HC-050-6-1	.50	6.0	24	Straight	
HC-050-6-TC-1	.50	6.0	24	Straight w/Type J Thermocouple	
HC-050-9-1	.50	9.0	36	Straight	
HC-050-9-TC-1	.50	9.0	36	Straight w/Type J Thermocouple	
HC-050-12-1	.50	12.0	48	Straight	
HC-050-12-TC-1	.50	12.0	48	Straight w/Type J Thermocouple	
HC-050-18-1	.50	18.0	72	Straight	
HC-050-18-TC-1	.50	18.0	72	Straight w/Type J Thermocouple	
HC-050-24-1	.50	24.0	96	Straight	
HC-050-24-TC-1	.50	24.0	96	Straight w/Type J Thermocouple	
HC-050-36-1	.50	36.0	144	Straight	
HC-050-36-TC-1	.50	36.0	144	Straight w/Type J Thermocouple	

*Dimensions in inches*

## Upstream Gas Line Insulators

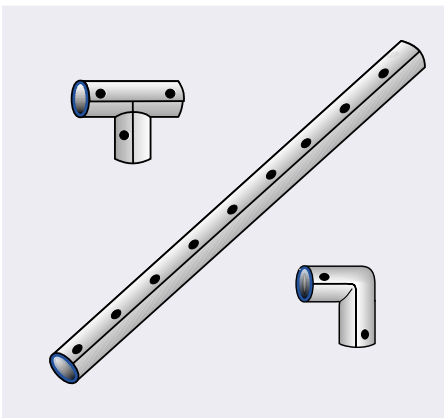

Model Number	Tube O.D.	Length	Features	Price
HI-025-18T	.25	18.0	Straight	
HI-050-18T	.50	18.0	Straight	
HI-025-7W-M	.25		Micro-tee	
HI-050-7W-M	.50		Micro-tee	
HI-025-2WC-M	.25		Micro-elbow	
HI-050-2WC-M	.50		Micro-elbow	

*Dimensions in inches*

Prices subject to change without notice. - International product pricing will vary.

THERMAL-LIT 11/01



Nor-Cal is your source for temperature controllers. Full control of the process is available through front panel controls including set points and alarms. PC control is available on select controllers using standard software programs. Thermostat control, thermal fuses, up-to-temperature sensors, etc. are available on request.

## General Specifications

- 1, 2, 4, 8, 16 and 32 zones standard. Custom zoning available
- 100 V to 240 V Line voltage
- Sensor Input for various thermocouple types
- Nema 4, 4x and 12 enclosure
- Digital readout display on most models
- Programmable alarm output
- Timer available on select models
- RS232 or RS485 serial communication available on most multi-zone controllers
- Three year warranty
- UL and CSA agency approvals



Pre-programmed controllers are available with alarms, remote communication packages and other custom features. (16 zone MLS controller shown)

## HC-935 Heater Controllers

HC-935 series digital indicating controllers are available with a single temperature sensor input from a thermocouple or RTD sensor, and dual control outputs. The outputs may operate in a variety of modes including: heat, cool, alarm and timer.

The timer function operates in a choice of delay-ON, delay-OFF, signal-ON or signal-OFF modes. Front panel lock capability rounds out the feature set. HC-935 controllers are available for one, two and four zones.

### Features

- 1/32 DIN package
- NEMA 4X
- Countdown timer
- Programmable alarms
- Universal power supply
- Small panel footprint
- ±0.25% accuracy
- Worldwide flexibility
- Low cost multi-zone temperature control

## The Effect of Temperature Excursion on Heater Life

**PID Controllers result in temperature control accuracy of ± 2°C, and extend heater element life by up to 10x.**

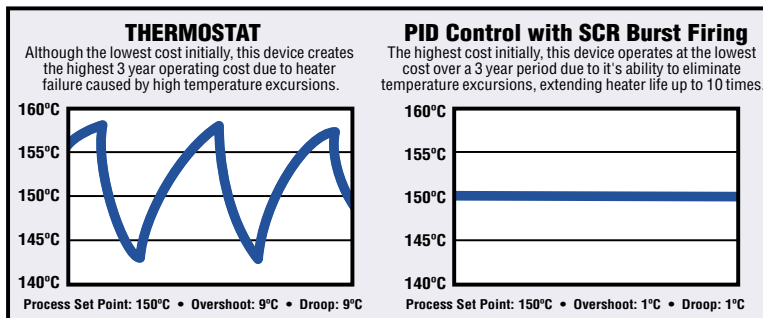

## Heater Controllers

Model Number	Description	Max. Output Watts@120V	Zones	Price
HC-935A-1-1	Self-contained microprocessor-based temperature control console. LED display.	960	1	
HC-935S-1-1	Self-contained microprocessor-based temperature control console. LED display.	1200	1	
HC-935A-2-1E	Self-contained microprocessor-based temperature control console. LED display.	1900	2	
HC-935A-4-1E	Self-contained microprocessor-based temperature control console. LED display.	1900	4	
HC-MLS2-8-1	Single multi-zone controller. RS232/485 compatible. Call for specifications.	Call	8	
HC-MLS2-16-1	16 zone control. Call for specifications.	Call	16	
HC-MLS2-32-1	32 zone control. Call for specifications.	Call	32	

Prices subject to change without notice. - International product pricing will vary.

THERMAL-LIT 11/01



## Custom Components

The experience gained designing heaters for our standard products has allowed us to provide thermal components for special applications. We have drawn from a number of heating technologies (silicon, fiberglass, cartridge, strip, band, tubular and thick film) in order to provide the most cost-effective solutions. Examples include heated traps, internal heaters for vacuum chambers, gas delivery systems, ion pump heaters, UHV bakeout tents for vacuum chambers, Kapton and tube heaters for heating inside the vacuum chamber and heater jackets for specific agency compliance, i.e. CE, NEC 427, Semi S2-93 and others.

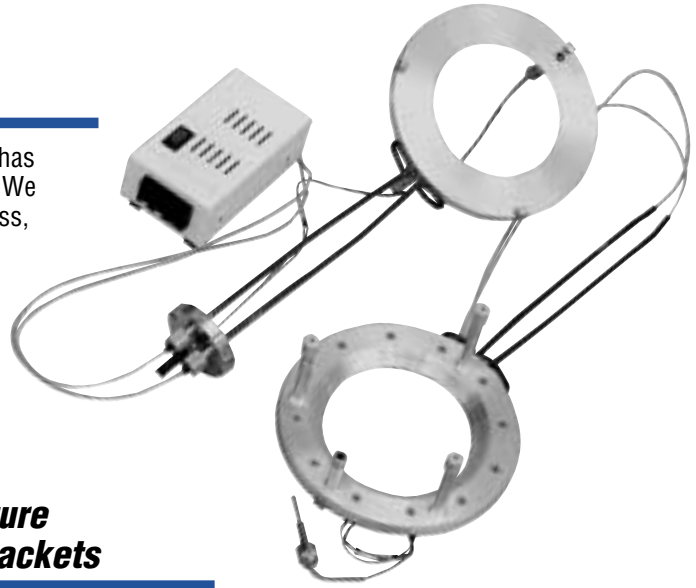

## High Temperature Cloth Heater Jackets

Nor-Cal offers a complete line of high temperature cloth heater jackets and insulators. Heating elements are helical wound resistive wire on a fiberglass core. This allows the wire to expand during thermal cycling with minimal metal fatigue. Jackets with fiberglass insulation and fiberglass based cloth can attain temperatures up to 482°C. Various types and thicknesses of insulation can be specified to meet specific requirements. A major benefit of cloth heater jackets is their durability and ease of removal/reinstallation for system cleaning and maintenance. Nor-Cal cloth heater jackets are sewn for an exact fit upon the piece to be heated or insulated. A helpful heater design worksheet is available on our Website at [www.n-c.com](http://www.n-c.com).



## Genesis Heaters and Insulators

The unique, CE certified Genesis modular heater provides 120°C or 150°C internal temperatures in valves or fittings at a fraction of the cost of a silicone heater. Genesis heaters use thick film technology to provide uniform heat throughout the component. Each heater contains a control set point and a resettable high temperature shut off. The 1.5 and 2.0 inch sizes also have a low temperature alert that can be connected to a remote alarm. Each thermostat can be replaced without destroying the heater. The same heater can be attached to a valve body or fitting with two screws. A trim-to-fit, molded insulator covers the heated component and mating flanges. These clean room compatible insulators are constructed of .50 inch thick molded silicone. When in use, the exterior surface remains touch-safe. Genesis Insulators meet UL 94 V-O requirements.

Teflon® is a registered trademark of E.I. du Pont de Nemours & Company.

Amp Mate-N-Lok® is a registered trademark of the Amp Company.

UL® is a registered trademark of Underwriters Laboratories, Inc.

Prices subject to change without notice. - International product pricing will vary.

THERMAL-LIT 11/01